

2 - Light Prewash

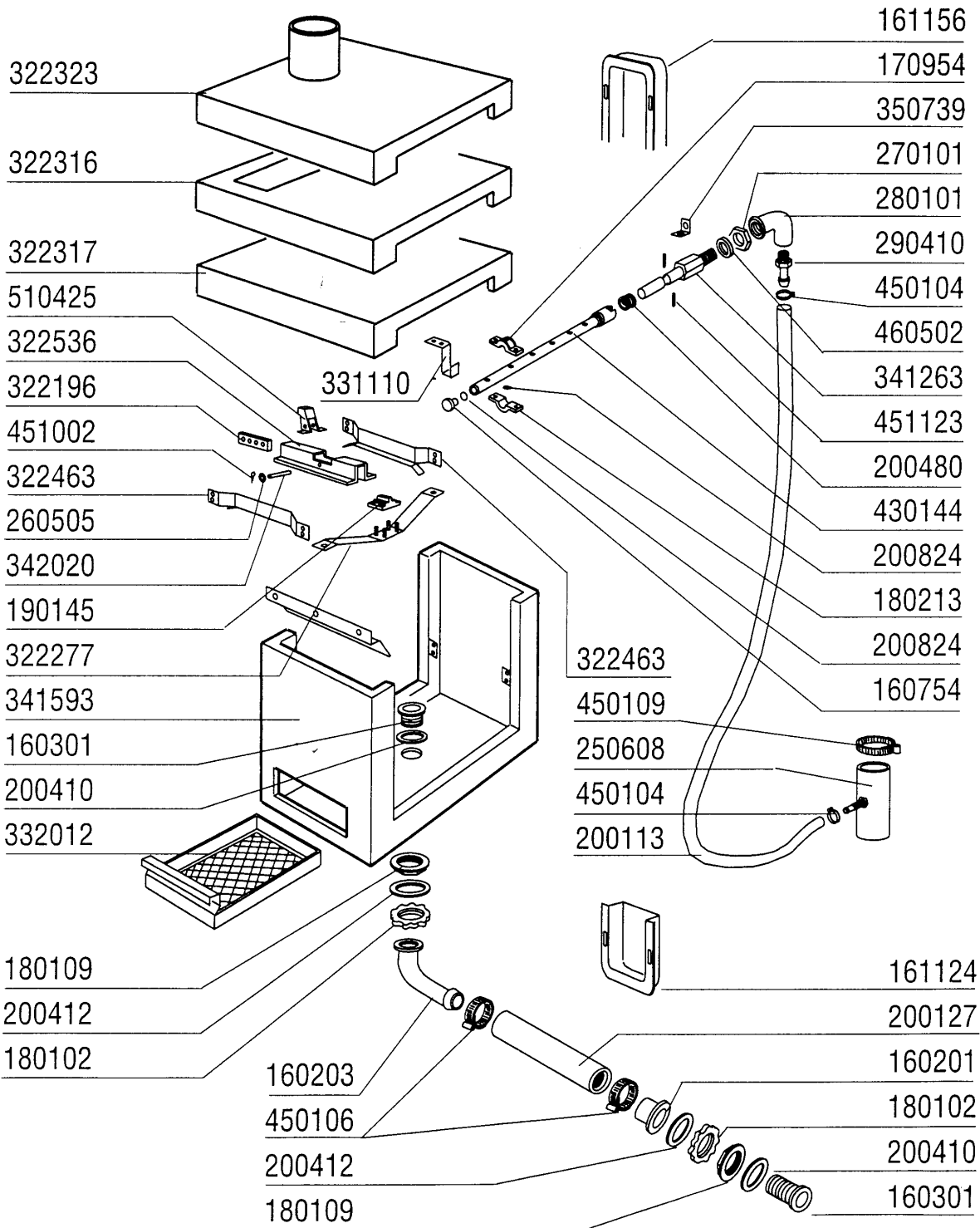

## 2 - Light Prewash

CODE	DESCRIPTION
160201	ELBOW F.TANK INLET MOPLEN
160203	ELBOW 1"1/2 N-S-F-C /DRAIN
160301	DRAIN OUTLET 1"1/2 C-S-N
160754	PLUG FOR RINSE ARMS SE NE
161124	DRYING OUTLET HOSE PROTECTION
161156	BACK COVER CHANNEL DETREMPE AC
170954	JET FOR ECORINSE ARM
180102	DRAIN PIPE NUT 1"1/2 F45-55
180109	LOCK NUT 1 1/2"
180213	FLANGE F.JET LOCKING F2-C34
190145	SUPPORT F.PAWL BAR GUIDE AC
200113	RUBBER HOSE 12 X 22
200127	PVC HOSE D.35
200410	DRAIN OUTL.WASH.1 1/2"65X47X2
200412	GASKET DRAIN 11/2" 45X33X3
200480	GASKET F. RINSE CONNECT.
200824	O-RING 1,78X12,42X15,98
250608	TEE PRE-WASH 400MM
260505	STAINL.STEEL FLAT WASHER D8
270101	HEXAGON LOCK NUT 1/2"
280101	CRANK F.F 1/2"
290410	NIPPLE 1/2"
322196	BRACKET
322277	SUPPORT FOR GUIDE AC
322316	TOP PANEL
322317	TOP PANEL
322323	TOP PANEL
322463	RACK GUIDE FOR PREWASH AC105
322536	PAWL BAR GUIDE AC
331110	SUPPORT.HOOK F.UPPER RINSE ARM
332012	DETREMPE FILTER DRAWER AC
341263	PIN
341593	PREWASH HOOD 400MM AC
342020	PIN
350739	BRACKET
430144	ECORINSE ARM SE
450104	CLAMP FE ZN H=12,5 15-24
450106	CLAMP FE ZN 32-44 H=12,2
450109	CLAMP 50-65
451002	COTTER PIN STAINL.ST. D2X12
451123	ELASTIC PIN 4X16
460502	GASKET 30X21X2
510425	PAWL LOAD. AC/ACR

3 - Wash Hood 1300mm

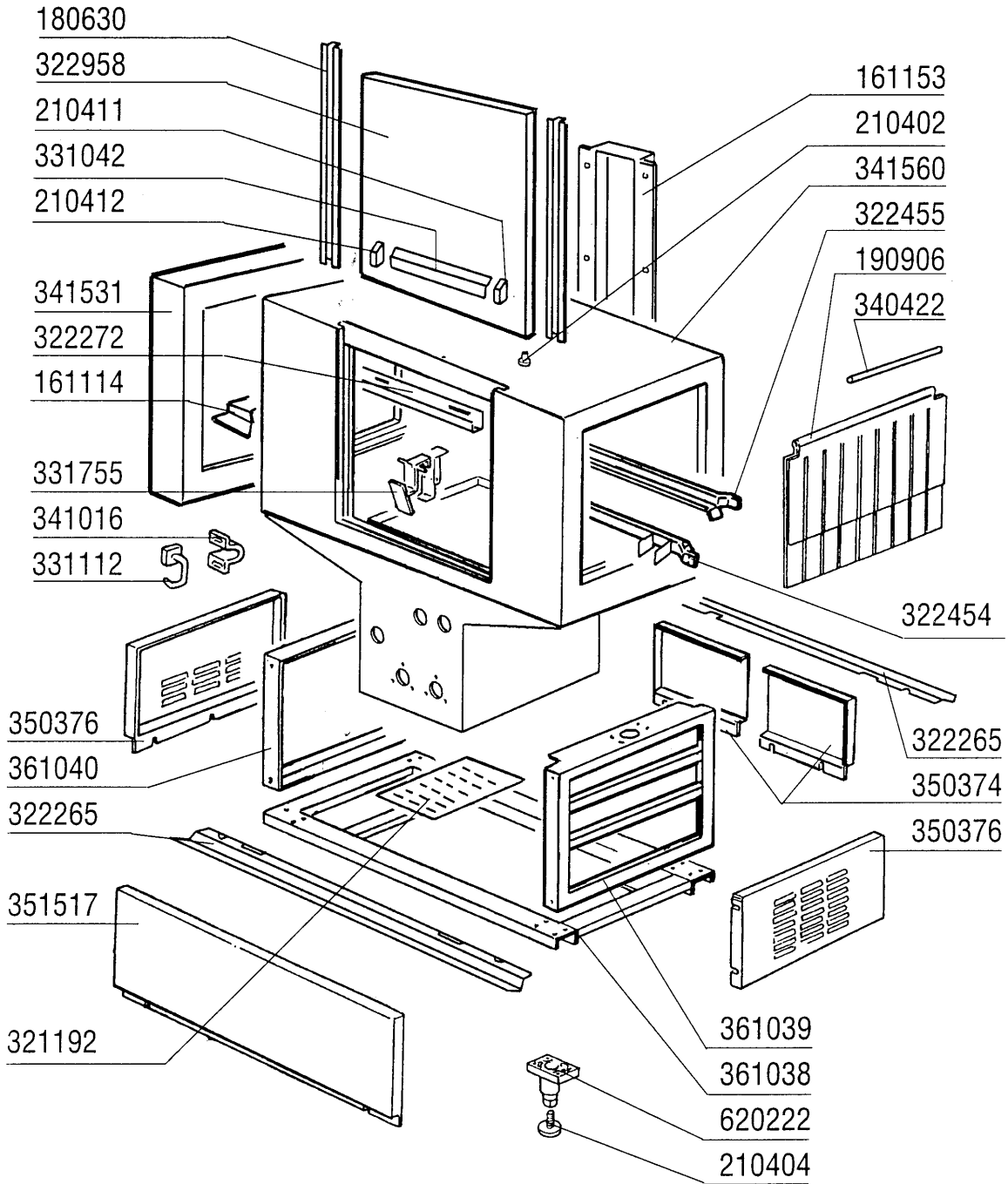

**3 - Wash Hood 1300mm**

<b>CODE</b>	<b>DESCRIPTION</b>
161114	END COVER OF PAWL BAR S3-S2900
161153	BACK COVER CHANNEL 300X1240 (S
180630	DOUBLE SKINNED DOOR RUNNER -AC
190906	CURTAIN IN/OUT 620X480
210402	PAD FOR DOOR 15-149
210404	BLACK RUBBER FOOT S90 NE SE
210411	RIGHT PLUG FOR ACR/AC HANDLE
210412	LEFT PLUG FOR ACR/AC HANDLE
321192	COVER FOR WIRING AC95/91
322265	SUPPORT
322272	SUPPORT GUARD AC95-105
322454	RACK GUIDE FOR AC95
322455	RACK GUIDE FOR AC95/105/135
322958	WASH/RINSE DOOR AC95
331042	DOOR HANDLE AC95/135
331112	HOOK (331116)
331755	HOOK FOR DOOR SUPPORT
340422	SHAFT FOR CURTAIN AC-ACR
341016	BRAKET FOR DOOR SECURITY HOOK
341531	HOOD
341560	HOOD AC95-105-135
350374	BACK PANEL AC
350376	LATERAL PANEL AC
351517	FRONT PANEL AC95
361038	CHASSIS FOR AC
361039	TANK CHASSIS AC
361040	TANK HOOD AC
620222	COMPLETE ALUMINIUM LEGS

4 - Blower Dryer hood

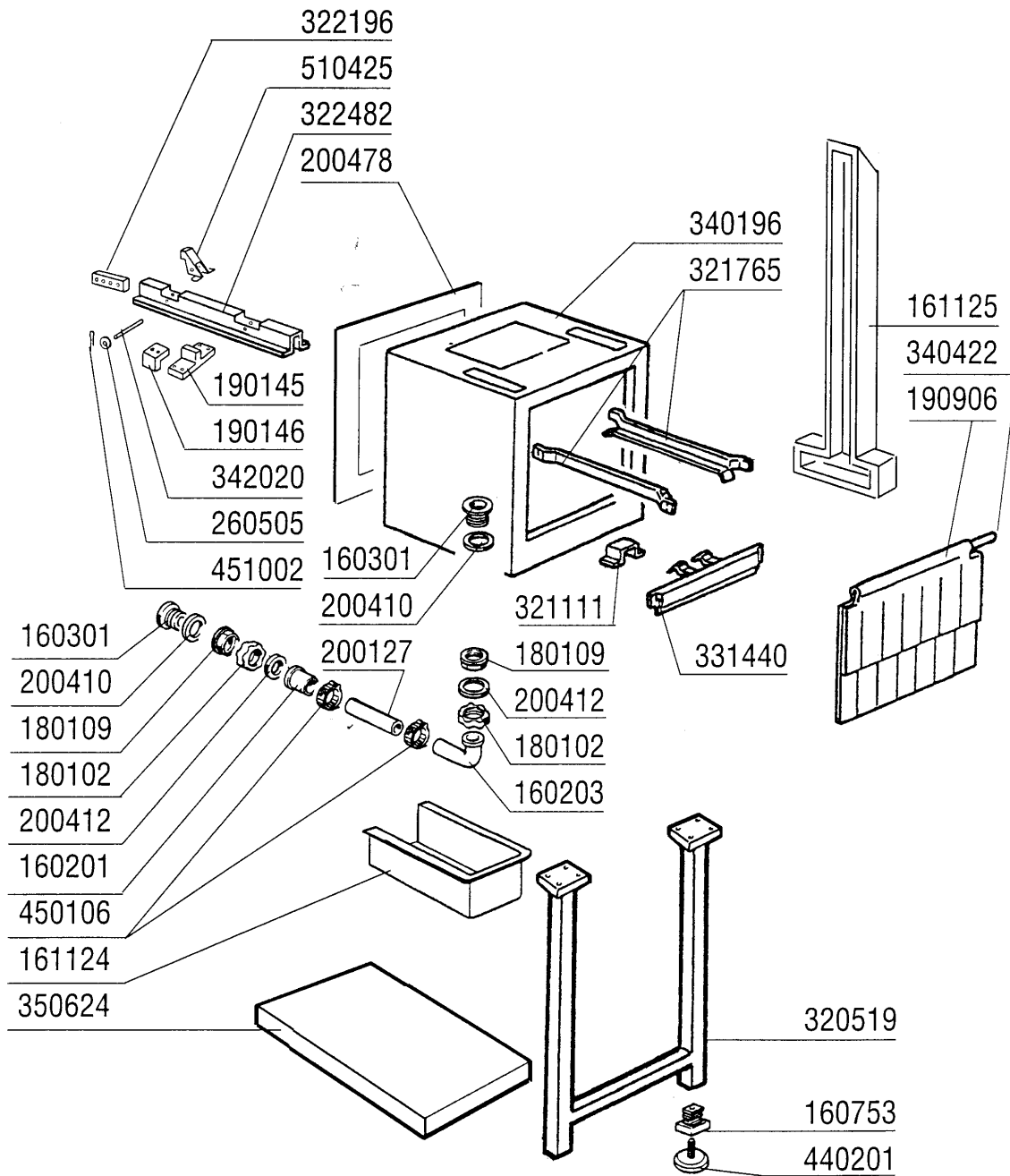

#### 4 - Blower Dryer hood

CODE	DESCRIPTION
160201	ELBOW F.TANK INLET MOPLEN
160203	ELBOW 1"1/2 N-S-F-C /DRAIN
160301	DRAIN OUTLET 1"1/2 C-S-N
160753	PLUG 40X40X1
161124	DRYING OUTLET HOSE PROTECTION
161125	BACK COVER CHANNEL S NL
180102	DRAIN PIPE NUT 1"1/2 F45-55
180109	LOCK NUT 1 1/2"
190145	SUPPORT F.PAWL BAR GUIDE AC
190146	CLAMPING PIECES AC
190906	CURTAIN IN/OUT 620X480
200127	PVC HOSE D.35
200410	DRAIN OUTL.WASH.1 1/2"65X47X2
200412	GASKET DRAIN 11/2" 45X33X3
200478	SELF-ADHESIVE GASKET 65X4
260505	STAINL.STEEL FLAT WASHER D8
320519	DRYER LEG SUPPORT
321111	COVER
321765	GUIDE
322196	BRACKET
322482	PAWL BAR GUIDE DRYER AC95/135
331440	PANEL
340196	DRYING HOOD
340422	SHAFT FOR CURTAIN AC-ACR
342020	PIN
350624	UNDER-TABLE
440201	RUBBER FOOT D.60X10
450106	CLAMP FE ZN 32-44 H=12,2
451002	COTTER PIN STAINL.ST. D2X12
510425	PAWL LOAD. AC/ACR

5 - Wash Assembly 1300mm

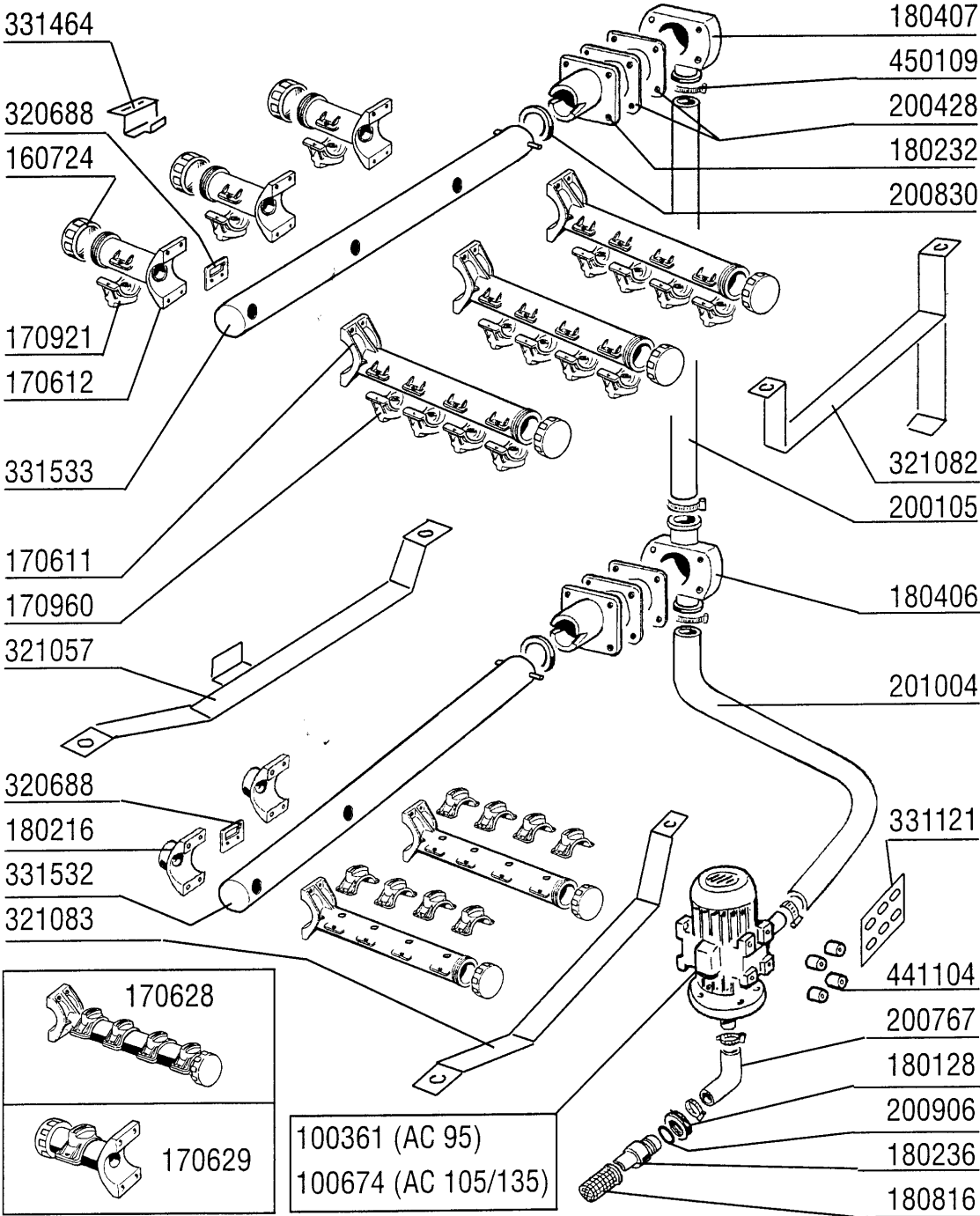

## 5 - Wash Assembly 1300mm

CODE	DESCRIPTION
100361	PUMP HP 2-220/380-50HZ-120404
100674	PUMP HP 3 V.220-415-50HZ-1205
160724	PLUG F. WASH ARM S90
170611	LONG WASH ARM S90 -S N L
170612	SHORT WASH ARM S90-S2900
170628	WASH ARM ASSEMBLY S1600
170629	SHORT WASH ARM ASSEMBLY
170921	AXIAL WASH NOZZLE D 35
170960	WASH JET 4,5
180128	RING NUT 65,4 C140 C85
180216	WASH ARM COUNTERFLANGE S90-S N
180232	WASH ARM FLANGE SNL
180236	PUMP SUCTION FOR AC-ACR-C155
180406	T-CONNECTOR F. WASHING S90-SNL
180407	ELBOW S90 S N L
180816	STRAINER OF INLET PUMP AC-ACR
200105	RUBBER HOSE 50X60
200428	GASKET 100X100X3 NEOTEN
200767	OUTLET HOSE WASH ACR
200830	O-RING 37,3X44,5X3,6
200906	GASKET D.92X66X2
201004	OUTLET HOSE AC95-AC135
320688	SUPPORT FOR S/AC WASHARM
321057	LOWER WASH ARM SUPPORT
321082	SUPPORT
321083	SUPPORT FOR "S" LOWER WASHARM
331121	FIXING PLATE FOR PUMP ACR
331464	SUPPORT FOR UPPER WASH ARM
331532	LOWER WASH ARM AC91/101
331533	UPPER WASH ARM AC91/101
441104	VIBRATION-DAMPING FEET FOR ACR
450109	CLAMP 50-65



6 - Rinse Assembly AC95

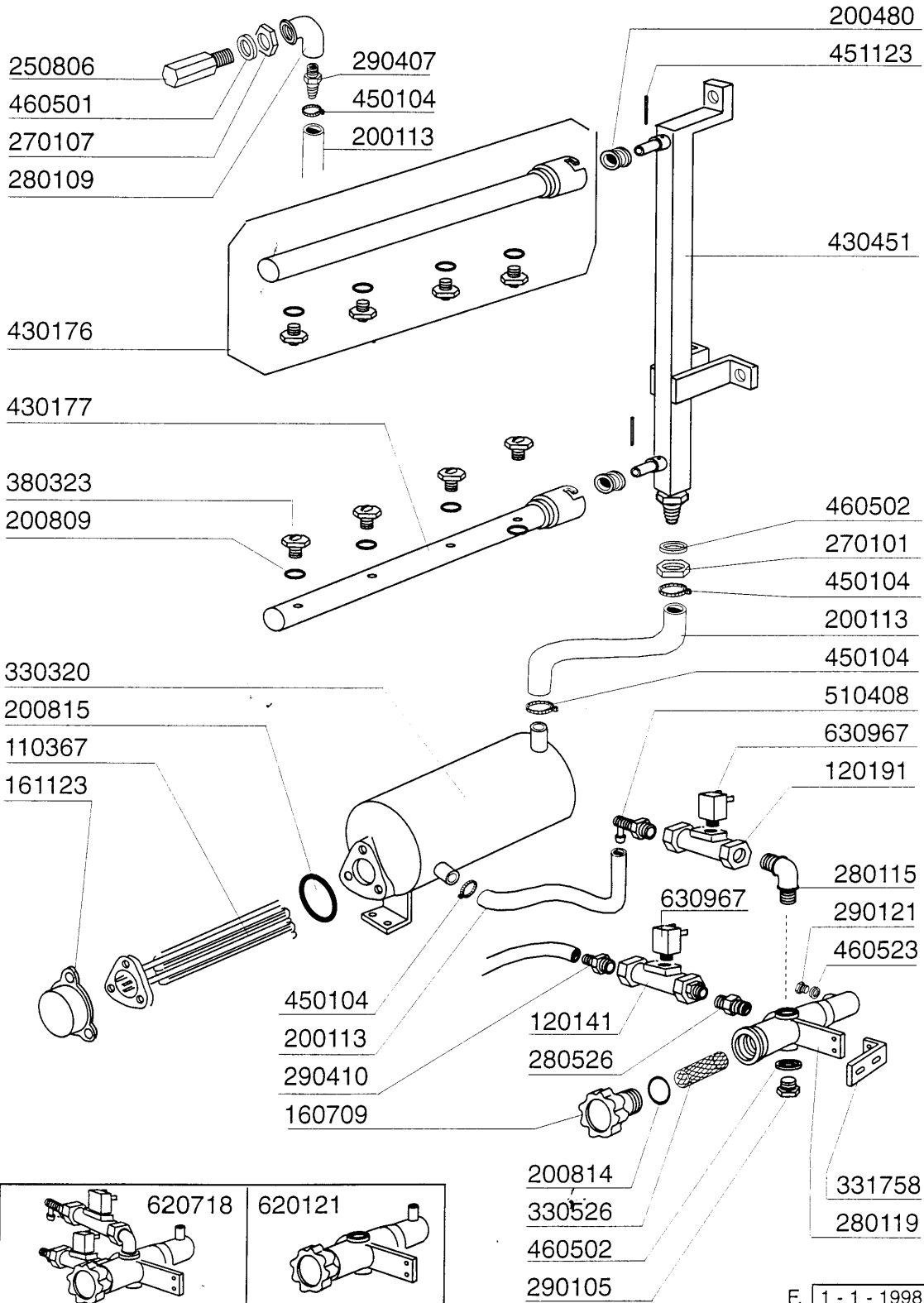

F. 1 - 1 - 1998

## 6 - Rinse Assembly AC95

CODE	DESCRIPTION
110367	HEAT.ELEMENT 12500W 230/400V
120141	SOLEN.VALVE METAL.328000 D.1/2
120191	SOLENOID VALVE AC95
160709	KNOB OF MANIFOLD F. SOLEN. VAL
161123	HEAT.ELEMENT COVER H42 SNL
200113	RUBBER HOSE 12 X 22
200480	GASKET F. RINSE CONNECT.
200809	OR GASKET 1,78X8,73X12,29
200814	O-RING 34,52X41,58X3,53
200815	O-RING F. HEAT.ELEM.
250806	TANK FILL HOSE CLAMP - AC/ACR
270101	HEXAGON LOCK NUT 1/2"
270107	BRASS LOCK NUT 3/8" FL803
280109	CRANK 90Ø F.F 3/8"
280115	ELL 1/2"
280119	ELL MF 3/4"
280526	CONNECTION 1/2-3/4"
290105	BRASS-TE-PLUG 1/2"
290121	BRASS PLUG 1/8"
290407	NIPPLE 3/8"
290410	NIPPLE 1/2"
330320	INSULATED BOILER D.1 164X650 S
330526	FILTERS 22X28 SOLENOID V.MANIF
331758	BRACKET F.SOLEN.VALV SE
380323	RINSE JETS 37.5 80Ø OV 1/8
430176	RINSE ARM
430177	RINSE ARM AC95-105
430451	RINSE COLUMN AC135
450104	CLAMP FE ZN H=12,5 15-24
451123	ELASTIC PIN 4X16
460501	GASKET 24X17X2
460502	GASKET 30X21X2
460523	GASKET 10X18X2
510408	CONNECTION 90Ø 1/2"
620121	TWIN SOLENOID VALVE MANIFOLD
620718	FILTER FOR SOLENOID AC
630967	COIL V24/50HZ E/V 328002

7 - Rinse Assembly AC95

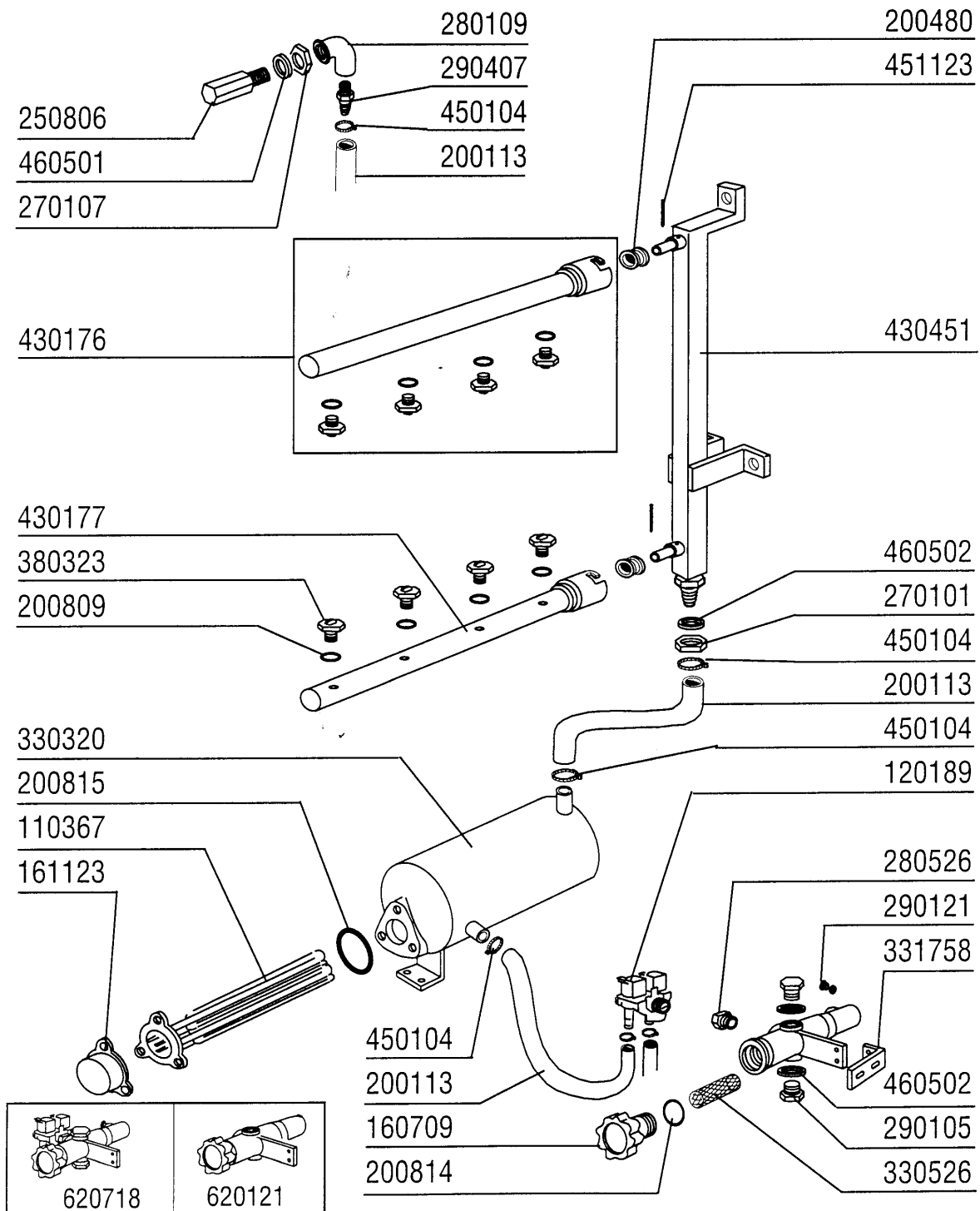

## 7 - Rinse Assembly AC95

CODE	DESCRIPTION
110367	HEAT.ELEMENT 12500W 230/400V
120189	2-WAY SOLEN.V.(120191+120141)
160709	KNOB OF MANIFOLD F. SOLEN. VAL
161123	HEAT.ELEMENT COVER H42 SNL
200113	RUBBER HOSE 12 X 22
200480	GASKET F. RINSE CONNECT.
200809	OR GASKET 1,78X8,73X12,29
200814	O-RING 34,52X41,58X3,53
200815	O-RING F. HEAT.ELEM.
250806	TANK FILL HOSE CLAMP - AC/ACR
270101	HEXAGON LOCK NUT 1/2"
270107	BRASS LOCK NUT 3/8" FL803
280109	CRANK 90Ø F.F 3/8"
280526	CONNECTION 1/2-3/4"
290105	BRASS-TE-PLUG 1/2"
290121	BRASS PLUG 1/8"
290407	NIPPLE 3/8"
330320	INSULATED BOILER D.1 164X650 S
330526	FILTERS 22X28 SOLENOID V.MANIF
331758	BRACKET F.SOLEN.VALV SE
380323	RINSE JETS 37.5 80Ø OV 1/8
430176	RINSE ARM
430177	RINSE ARM AC95-105
430451	RINSE COLUMN AC135
450104	CLAMP FE ZN H=12,5 15-24
451123	ELASTIC PIN 4X16
460501	GASKET 24X17X2
460502	GASKET 30X21X2
620121	TWIN SOLENOID VALVE MANIFOLD
620718	FILTER FOR SOLENOID AC

## 8 - Wash Tank Components

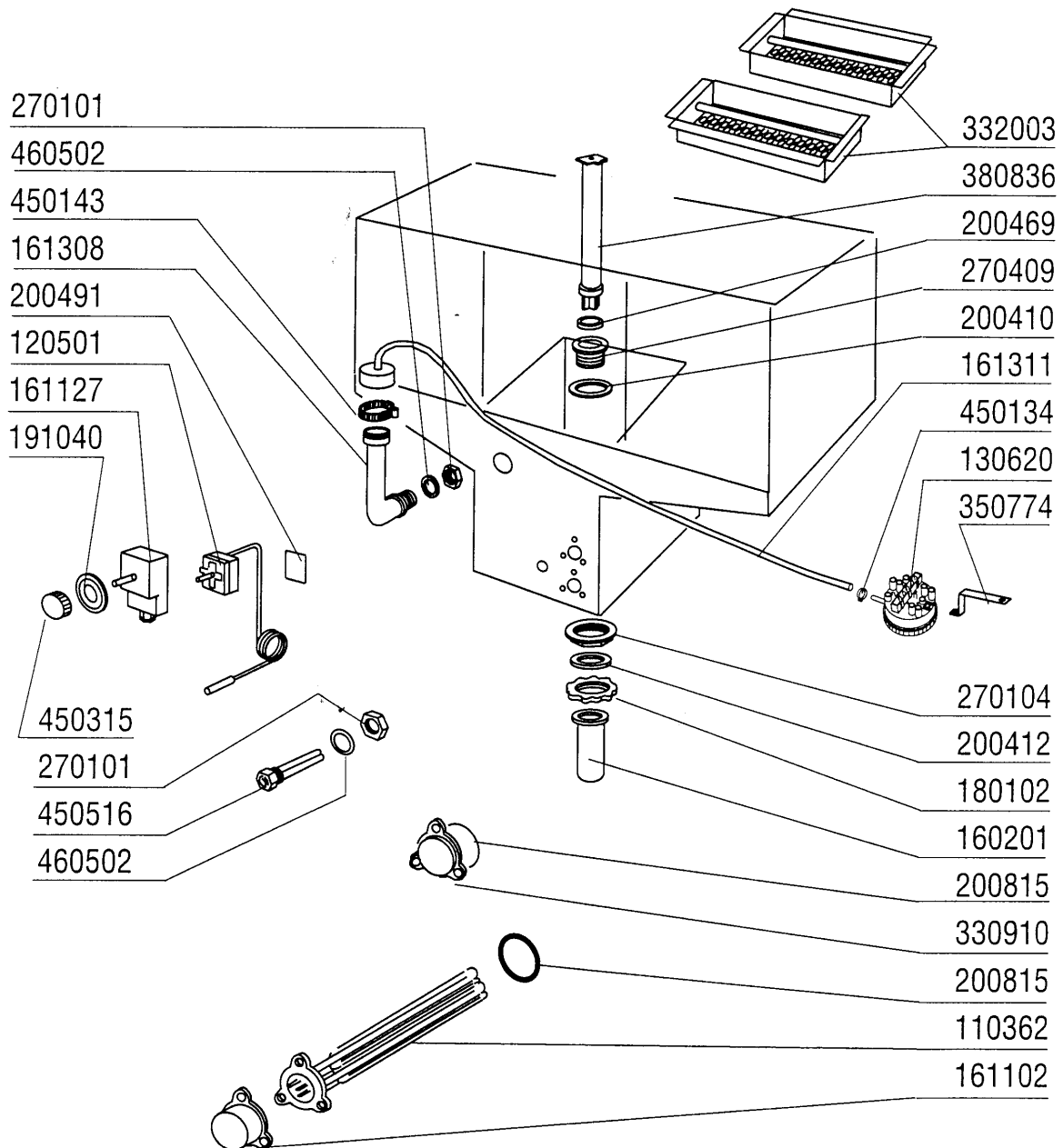

## 8 - Wash Tank Components

CODE	DESCRIPTION
110362	HEAT.ELEMENT 9000W 220/380V
120501	THERMOSTAT 30/90°C
130620	PRESSURE SWITCH 3 LEVEL 50-30/
160201	ELBOW F.TANK INLET MOPLN
161102	ELEMENT COVER MOPL.
161127	BOX FOR THERMOSTAT
161308	AIR CHAMBER C95-155
161311	HOSE FOR AIR CHAMBER BC-BR-AC9
180102	DRAIN PIPE NUT 1"1/2 F45-55
191040	FRAME F.THERMOSTAT KNOB
200410	DRAIN OUTL.WASH.1 1/2"65X47X2
200412	GASKET DRAIN 1 1/2" 45X33X3
200469	STAND PIPE O RING 45X35,5X7
200491	BACK GASKET OF THERMOSTAT BOX
200815	O-RING F. HEAT.ELEM.
270101	HEXAGON LOCK NUT 1/2"
270104	LOCK NUT 1" 1/2
270409	DRAIN OUTLET AC-ACR
330910	FLANGE
332003	WASH STRAINER AC95/91/181
350774	BRACKET
380836	OVERFLOW PIPE MM.415
450134	ELASTIC HOSE CLIP D.9,3/8,8
450143	CLAMP D.39,7 X 37,7
450315	KNOB F. THERMOSTAT 90°
450516	THERMOSTAT SHIELD FOR 2 TERMOS
460502	GASKET 30X21X2

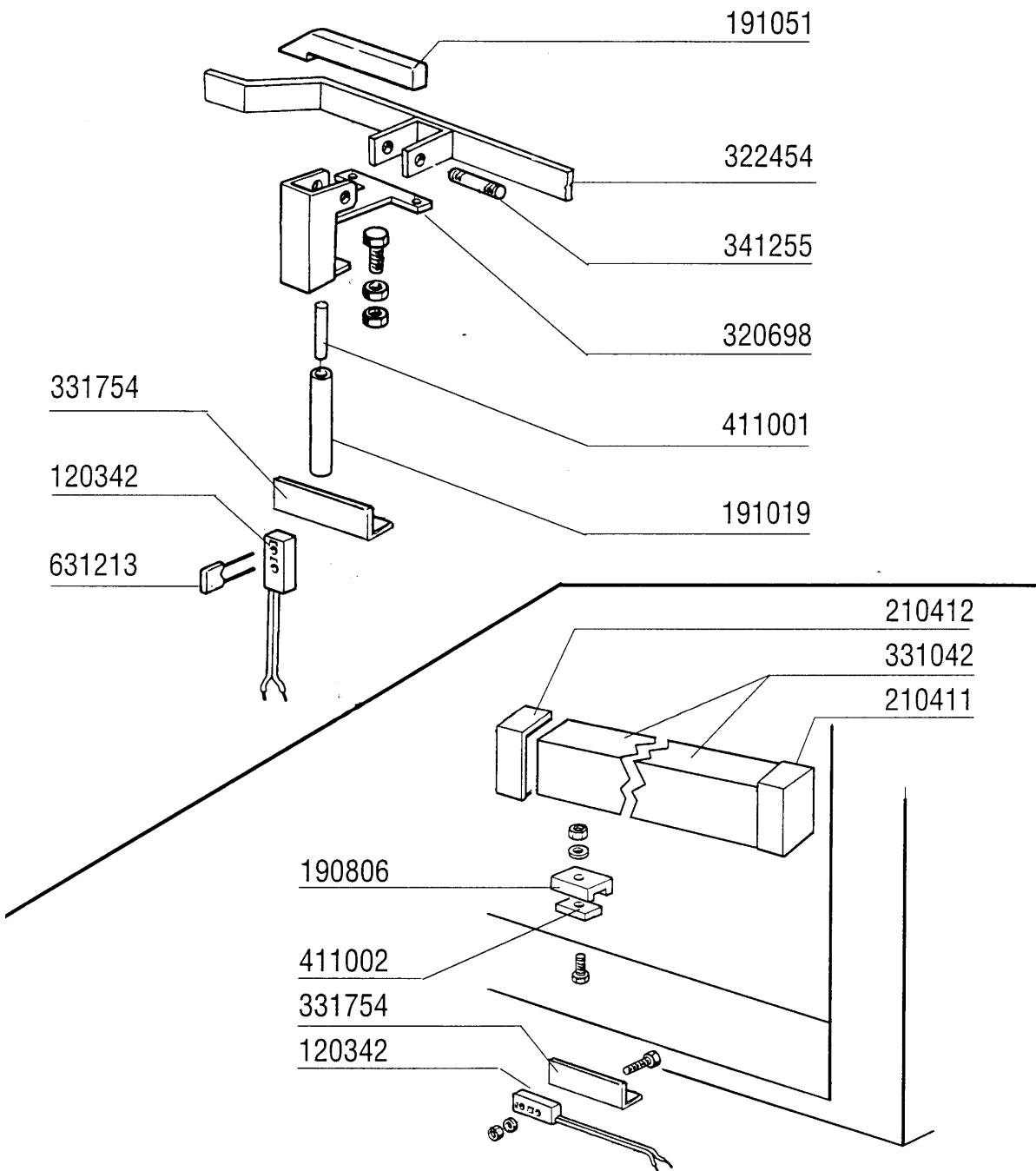

**9 - Economiser**

<b>CODE</b>	<b>DESCRIPTION</b>
120342	DOR MAGNETIC SWITCH
190806	MAGNET HOUSING
191019	MAGNET HOUSING S90 MOPL.-S.N.L
191051	SLIDING PAD SE SNL ECONOMIZER
210411	RIGHT PLUG FOR ACR/AC HANDLE
210412	LEFT PLUG FOR ACR/AC HANDLE
320698	LEVER FOR ECONOMIZER SE SNL
322454	RACK GUIDE FOR AC95
331042	DOOR HANDLE AC95/135
331754	DOOR MICRO SWITCH BRACKET FOR
341255	PIN FOR ECONOMIZER SE SNL
411001	PERMANENT MAGNET 8X40
411002	PERMANENT MAGNET 24X12
631213	CAPACITOR 0,1MF



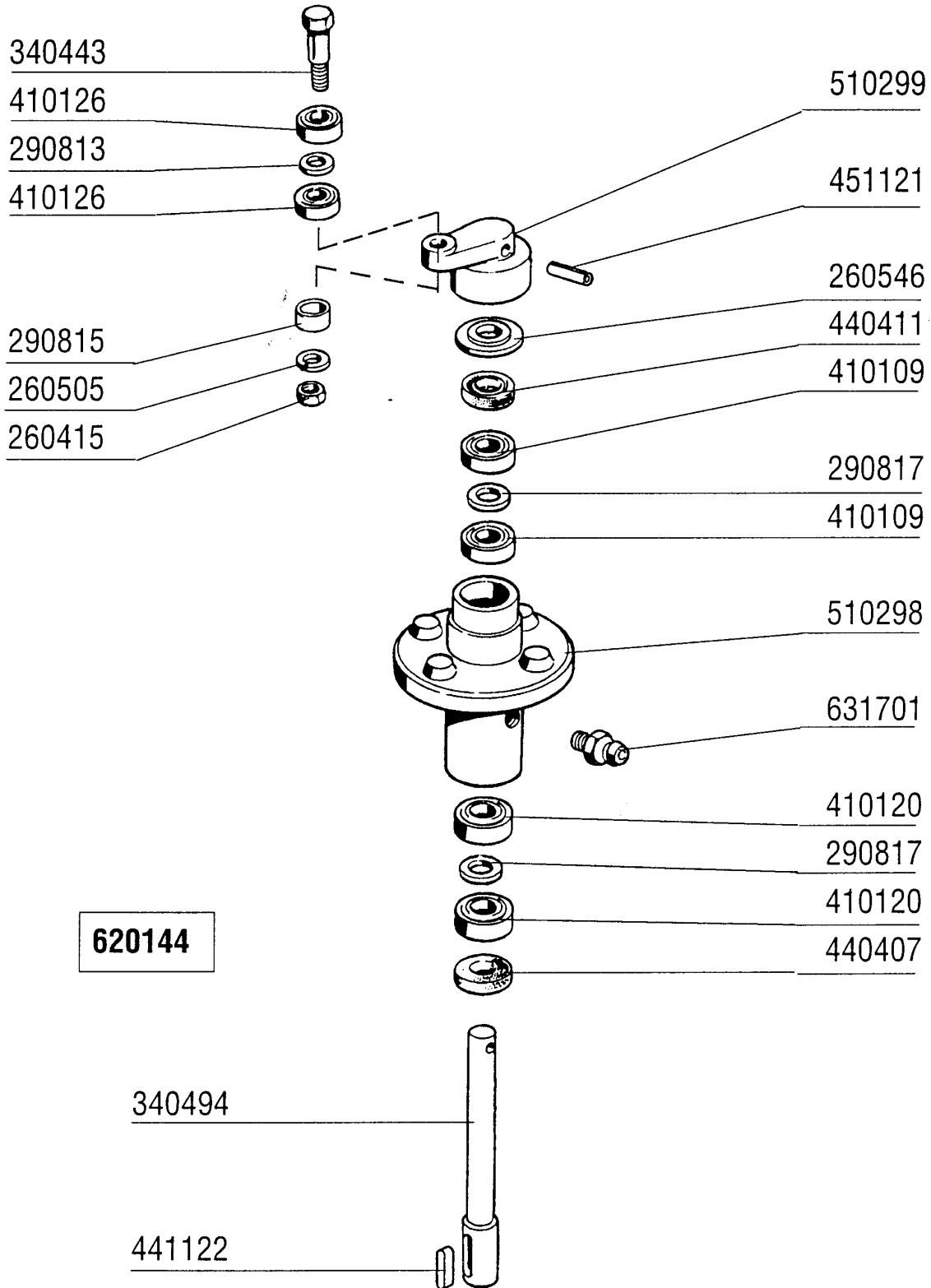

10 - Drive unit

CODE	DESCRIPTION
260415	STAINLESS STEEL SELF-LOCKING N
260505	STAINL.STEEL FLAT WASHER D8
260546	SLIDING WASHER STAINLESS STEEL
290813	PACKING PIECES BRASS S-F2
290815	DISTANCE PIECE S3Ø BRASS
290817	BRASS DISTANCE PIECE 24X14
340443	CRANK SHOULDER PIN
340494	DRIVE SHAFT S 3Ø
410109	BEARINGS 17X40X12 6203
410120	BALL BEARING 17X35X10
410126	BEARING 6201-2RS Z15
440407	SEAL MIM 20X35X7
440411	SEAL 17X40X7
441122	DRIVE SHAFT KEY 6X6X25 UNI 660
451121	ELAST.ROLL PINS 6X30
510298	DRIVE HOUSING S 3Ø
510299	NICKELPLATED BRASS DRIVE CRANK
620144	DRIVE ASSEMBLY
631701	GREASE NIPPLE 9003

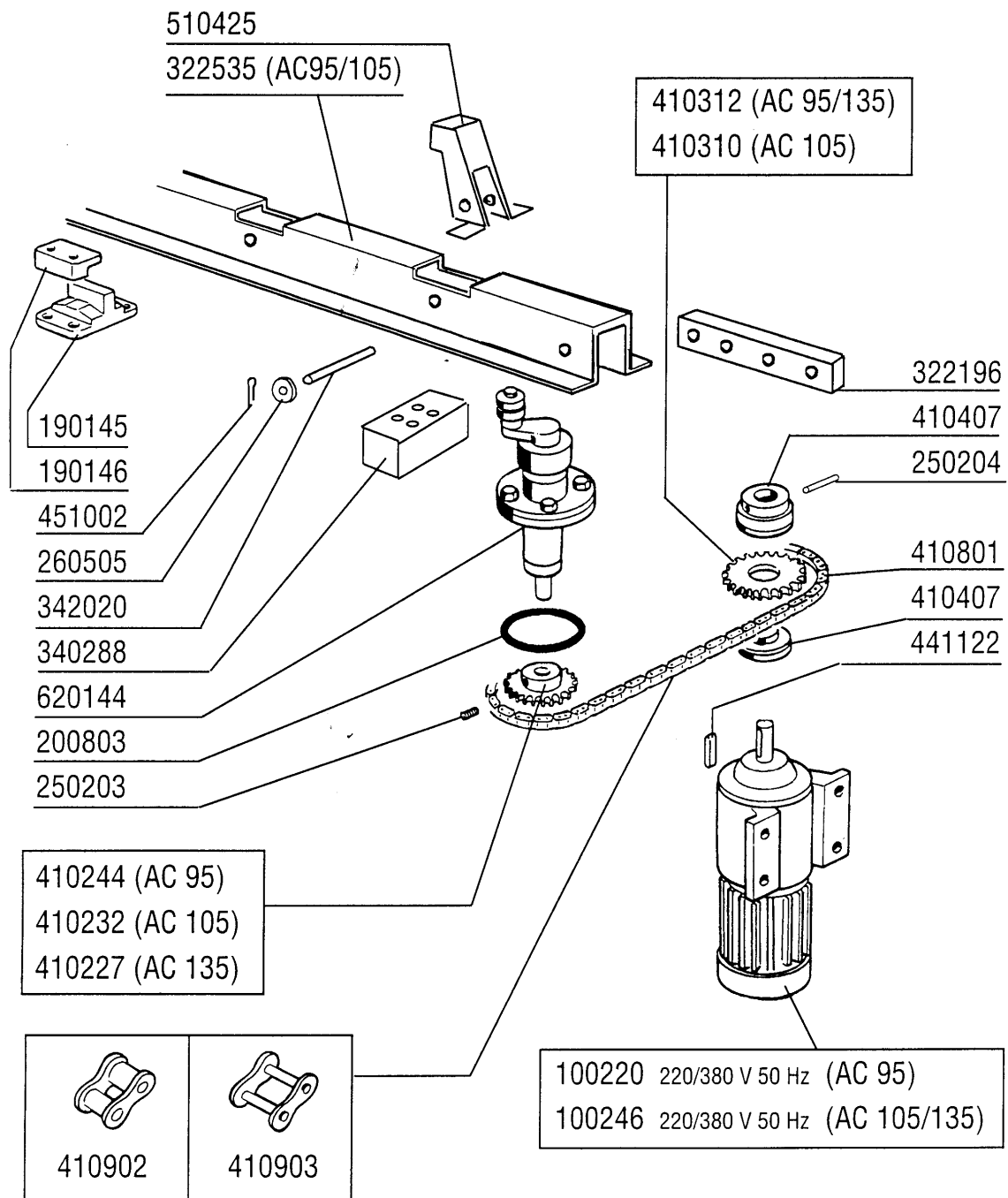

## 11 - Drive unit

CODE	DESCRIPTION
100220	DRIVE MOTOR KW0,12-220/380V/50
100246	DRIVE KW 0,1-0,15 380/3
190145	SUPPORT F.PAWL BAR GUIDE AC
190146	CLAMPING PIECES AC
200803	OR GASKET 3,53X98,02X105,08
250203	GRUB SCREW 8X12
250204	GRUB SCREW 6X6
260505	STAINL.STEEL FLAT WASHER D8
322196	BRACKET
322535	PAWL BAR GUIDE AC
340288	CHANNEL F.DRIVE BEARING S3Ø-SE
342020	PIN
410227	TURNED PINION Z16-1/2"-D.20
410232	TURNED PINION Z25-1/2"-D.20
410244	PINION Z34
410310	CROWN Z 26 1/2"
410312	CROWN DISCS 22T
410407	TORQUE LIMITER LC 1
410801	DRIVE CHAIN 1/2" N-S
410902	FALSE CHAIN LINK 1/2"
410903	CHAIN JOINT 1/2"
441122	DRIVE SHAFT KEY 6X6X25 UNI 660
451002	COTTER PIN STAINL.ST. D2X12
510425	PAWL LOAD. AC/ACR
620144	DRIVE ASSEMBLY

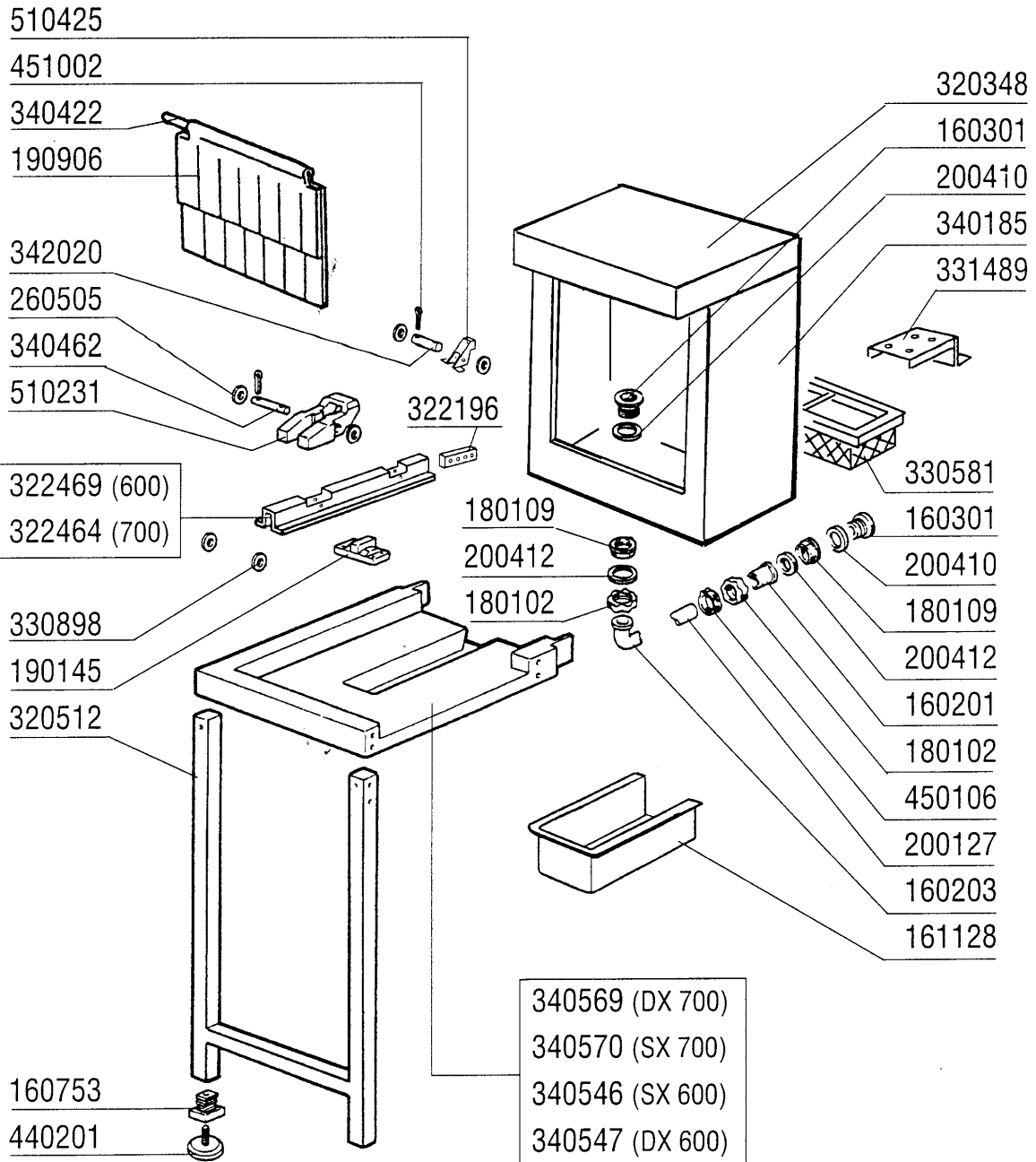

## 12 - Side Loading Table

CODE	DESCRIPTION
160201	ELBOW F.TANK INLET MOPLEN
160203	ELBOW 1"1/2 N-S-F-C /DRAIN
160301	DRAIN OUTLET 1"1/2 C-S-N
160753	PLUG 40X40X1
161128	SPLASH HOOD DRAIN PROTECTION A
180102	DRAIN PIPE NUT 1"1/2 F45-55
180109	LOCK NUT 1 1/2"
190145	SUPPORT F.PAWL BAR GUIDE AC
190906	CURTAIN IN/OUT 620X480
200127	PVC HOSE D.35
200410	DRAIN OUTL.WASH.1 1/2"65X47X2
200412	GASKET DRAIN 1 1/2" 45X33X3
260505	STAINL.STEEL FLAT WASHER D8
320348	BASE TOP FOR SPLASH HOOD
320512	TABLES LEG
322196	BRACKET
322464	PAWL BAR GUIDE 700MM
322469	PAWL BAR GUIDE 600MM AC
330581	DRAWER FILTER EXTENTION HOODS
330898	BUSH
331489	BRACKET
340185	HOOD
340422	SHAFT FOR CURTAIN AC-ACR
340462	SHORT TRAY CARRIER PIN GM-S290
340546	CORNER ENTRY TABLE 600MM LEFT
340547	CORNER ENTRY TABLE 600MM RIGHT
340569	CORNER ENTRY TABLE 700MM RIGHT
340570	CORNER ENTRY TABLE 700MM LEFT
342020	PIN
440201	RUBBER FOOT D.60X10
450106	CLAMP FE ZN 32-44 H=12,2
451002	COTTER PIN STAINL.ST. D2X12
510231	PAWL /CORNER LOAD.
510425	PAWL LOAD. AC/ACR

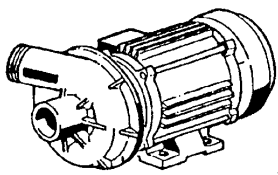

100361 (220/380 V 50 Hz)  
(240/415 V 50 Hz)

100605 (220/380 V 60 Hz)

100613 (250/440 V 60 Hz)

631618 (50 Hz)  
631647 (60 Hz)

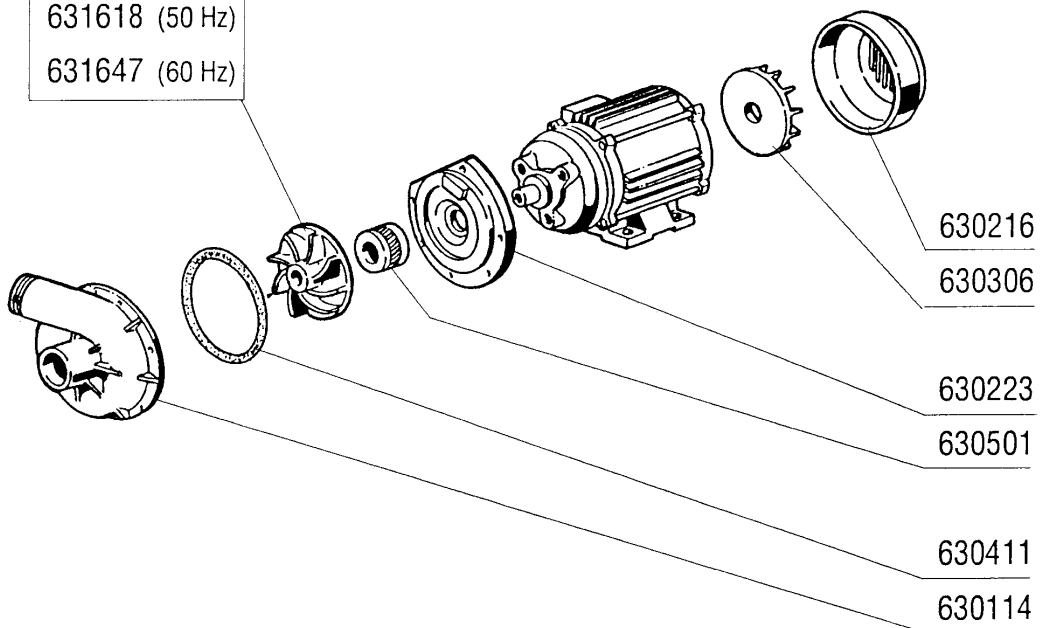

**13 - Pump 2HP**

<b>CODE</b>	<b>DESCRIPTION</b>
100361	PUMP HP 2-220/380-50HZ-120404
100605	PUMP HP 2 380/3/60HZ 1204
100613	PUMP HP 2 440/3/60HZ 1204
630114	VOLUTE FI HP2-2,7-3-3,2
630216	FAN HOUSING FIR HP 2-3
630223	BACK PLATE PUMP HP2-3-3,2
630306	PUMP FAN IMPELLOR FI HP.2-3
630411	O-RING PUMP FI HP 2-2,7
630501	SEAL FOR PUMP HP 2-3-3,2
631618	IMPELLER PUMP F HP2-D.116,5
631647	IMPELLER D.100-60HZ-1204/5



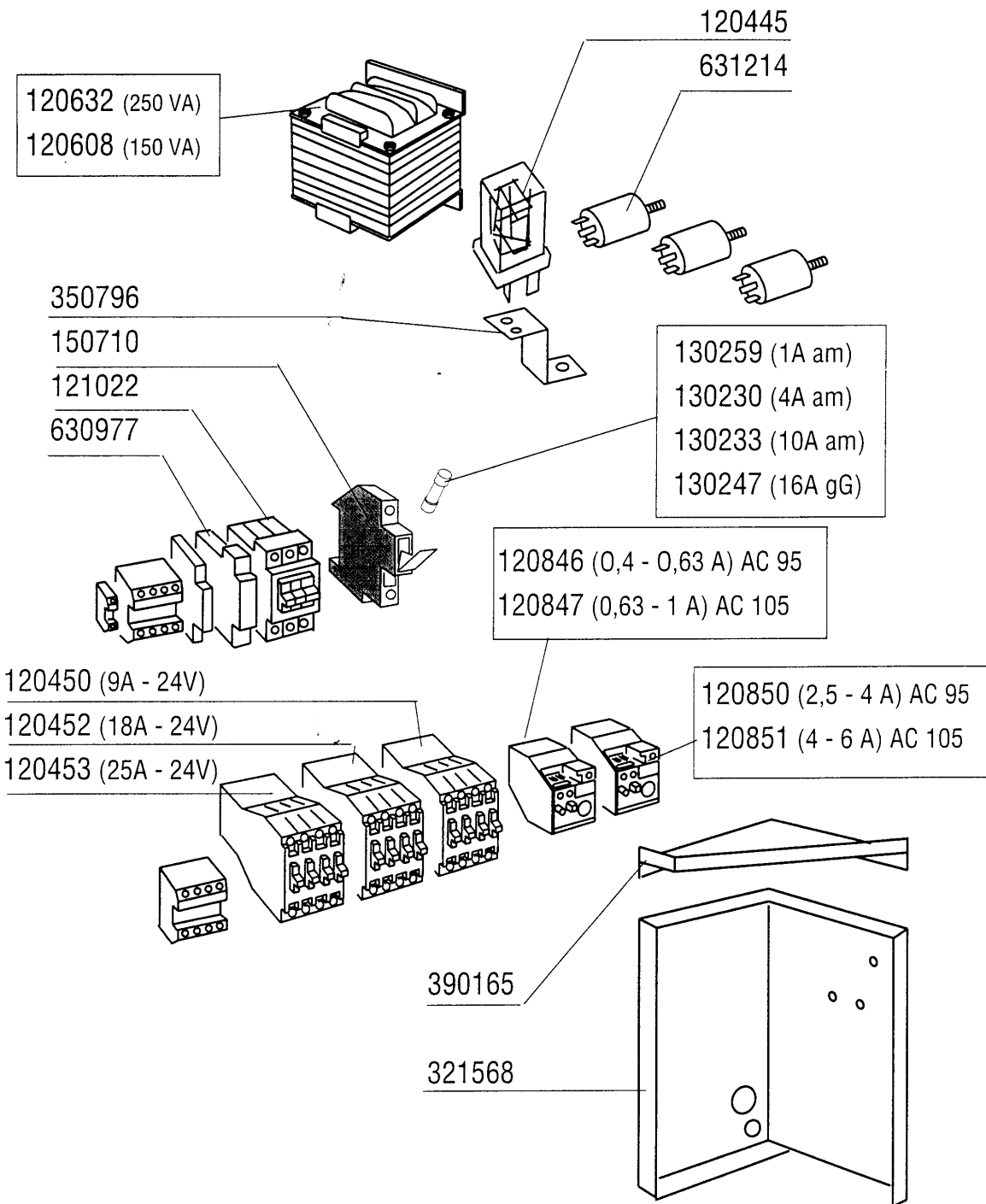

## 14 - Control Box

CODE	DESCRIPTION
120445	AUXILIARY RELAY S.B2/3 24V
120450	CONTACTOR 9A 24V 4KW
120452	CONTACTOR 18A 24V 7,5KW 3TF320
120453	CONTACTOR 25A 24V 11KW 3TF3300
120608	TRANSFORMER 150VA220-240-380-4
120632	TRANSFORMER 250VA220-240-380-4
120846	OVERLOAD RELAY 0,4/0,63A
120847	OVERLOAD RELAY 0,63/1A
120850	OVERLOAD RELAY 2,5/4A
120851	OVERLOAD RELAY 4/6A
121022	CIRCUIT BREAKER 32A
130230	FUSE 10,3X38 4A AM13004
130233	FUSE 10,3X38 10A AM13010
130247	FUSE 10.3X38 16A GF13316
130259	FUSE 10,3X38 1A AM 13095
150710	FUSE CARRIER 10,3X38 ART.21401
321568	SUPPORT WIRING AC95/105
350796	BRACKET F. RELAY SUPPORT S
390165	PANEL PROTECT.FOR CONTROL BOX
630977	COIL FOR CIRCUIT BREAKER 24V
631214	ANTI-NOISE FILTER 4011135007 3

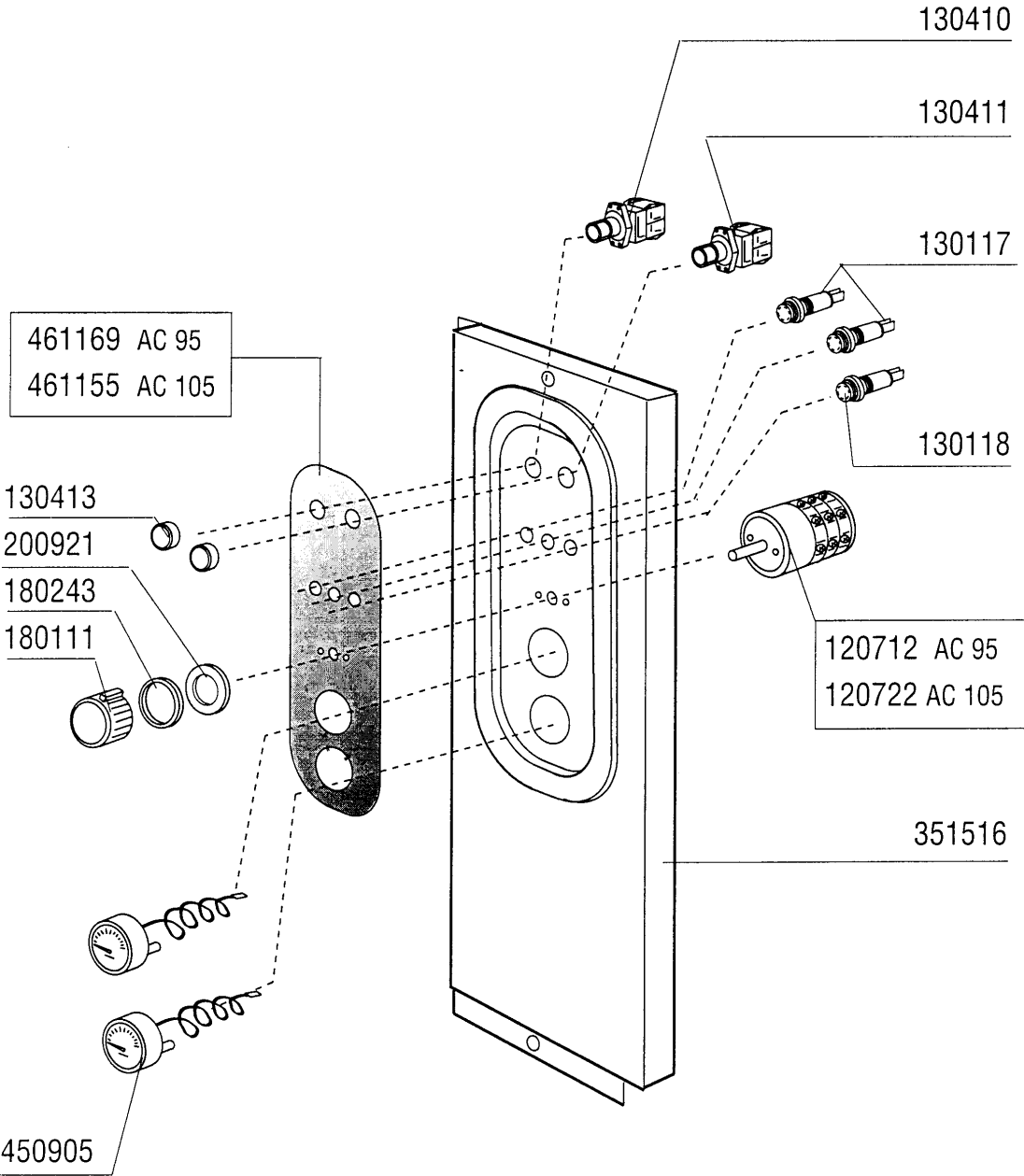

## 15 - Control panel AC95 - AC105

CODE	DESCRIPTION
120712	2-POLES SWITCH 16AMP
120722	6 POLE SWITVH 2 POSITIONS
130117	GREEN LIGHT 24V S90-G66
130118	RED LIGHT 24V S90 - G66
130410	STOP CONTACT F40 CN RED
130411	START CONTACT YELLOW
130413	GREEN PUSH BUTTON
180111	BLACK KNOB
180243	FLANGE
200921	GASKET
351516	CONTROL PANEL AC95
450905	CAPIL.THERMOMETER D.52 1,5M
461155	CONTROL PANEL AC105
461169	CONTROL PANEL AC95

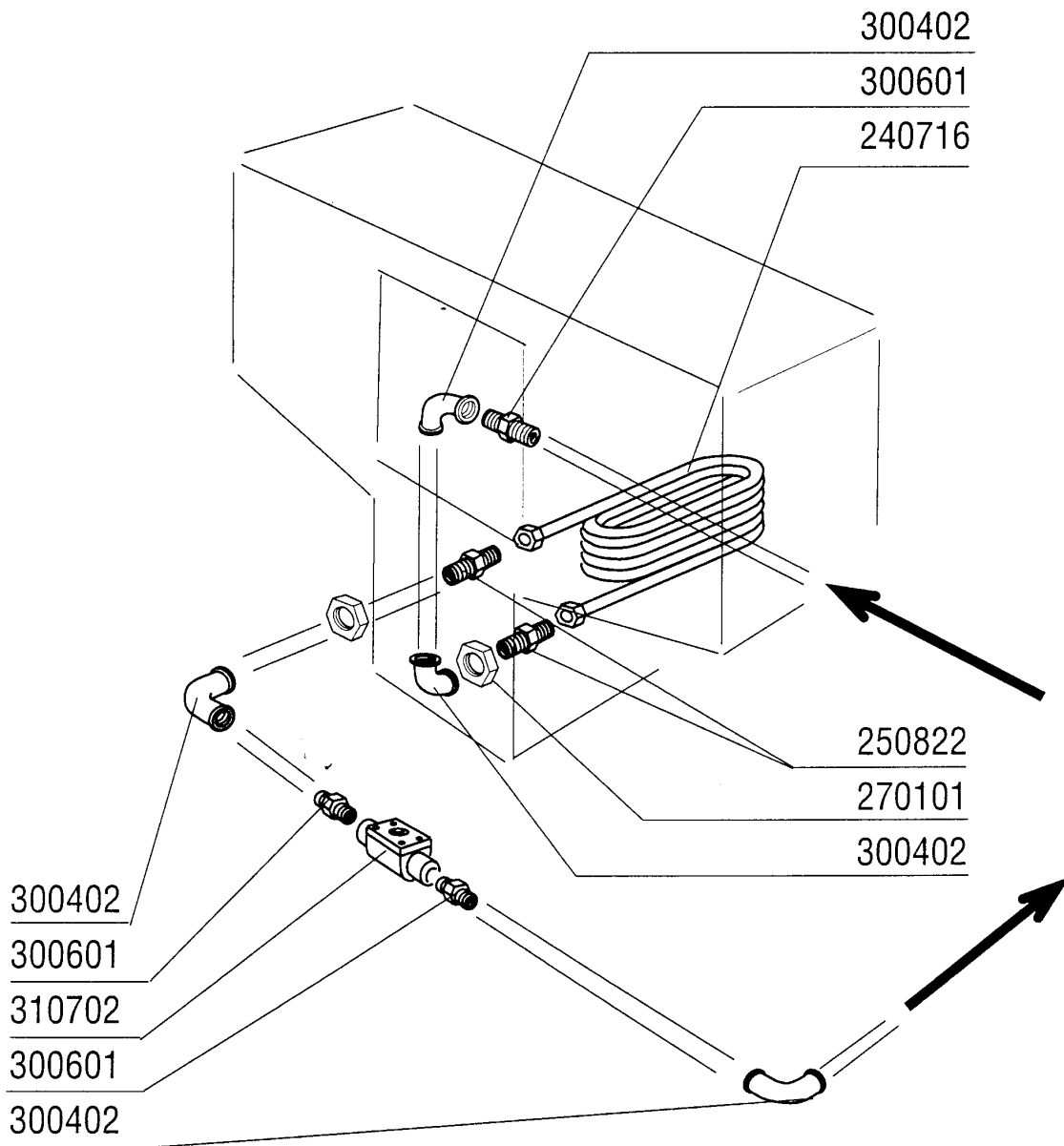

16 - Steam Version

CODE	DESCRIPTION
240716	STEAM COIL G66-S3
250822	EXTENSION 1/2"
270101	HEXAGON LOCK NUT 1/2"
300402	ELL FF 1/2"
300601	PIPE UNION 1/2"
310702	STEAM TRAP 1/2" MK 25/3

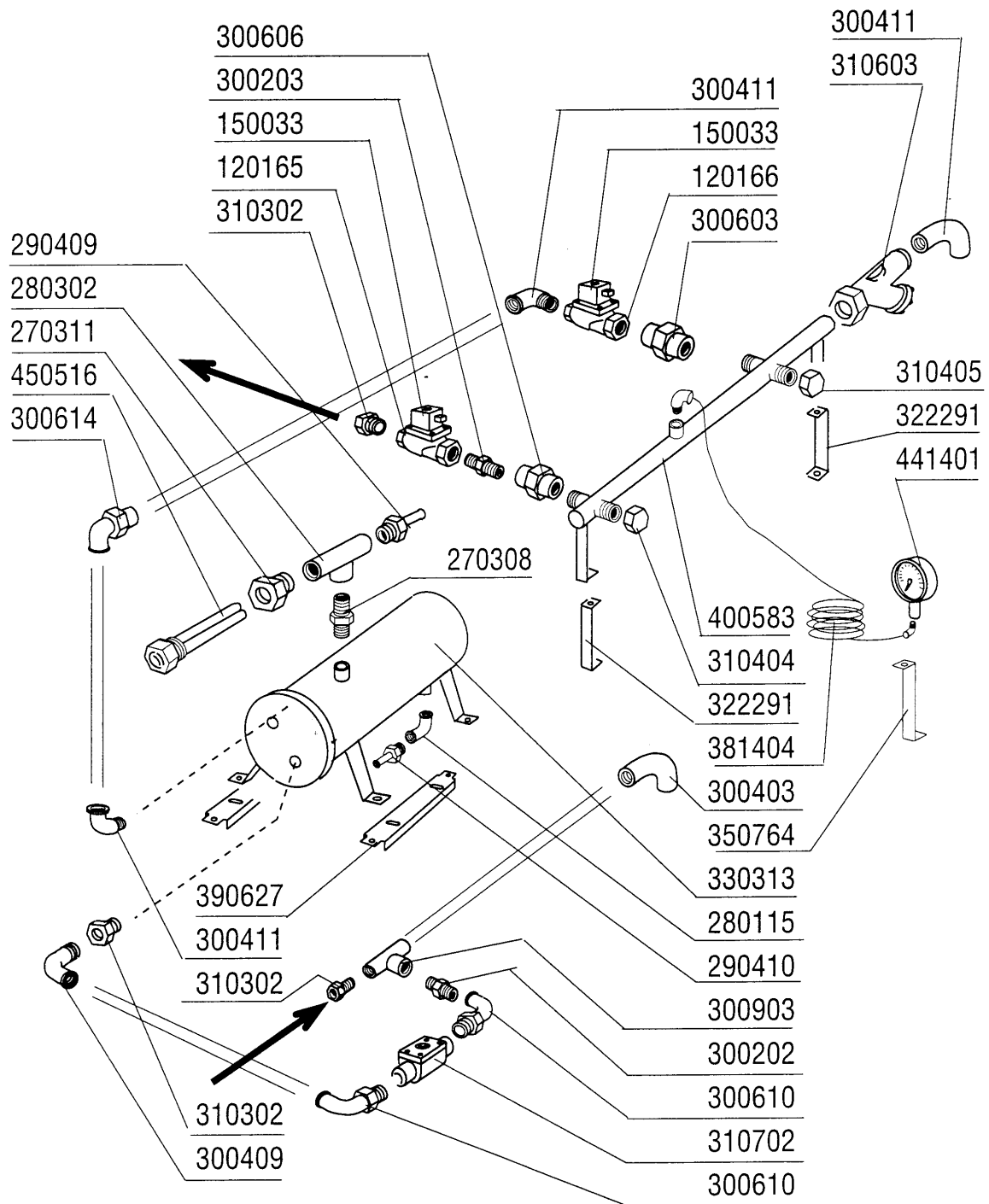

17 - Steam Version

CODE	DESCRIPTION
120165	SOLE.N.VALVE ST.24V50HZ 3/4"
120166	STEAM SOLEN.VALVE 1" 24V-50
150033	CONNEC.F.SOLEN.VALVE 182.09.N
270308	NIPPLES 3/4"
270311	NIPPLE 3/4"-1/2"
280115	ELL 1/2"
280302	HOSE CLAMPS STRAIGHT 3/4"
290409	NIPPLE 3/4"
290410	NIPPLE 1/2"
300202	NIPPLE 3/4"-1/2"
300203	NIPPLE 3/4"-1"
300403	ELL FF 3/4"
300409	ELL MF 1/2"
300411	ELL 1"
300603	PIPE UNION MF 1"
300606	PIPE UNION FF1"
300610	PIPE UNION 1/2"
300614	ELL F.F. 1
300903	TEE 3/4"
310302	NIPPLE 3/4"-1/2"
310404	COVER
310405	COVER
310603	STRAINERS JU 1" MOD.45
310702	STEAM TRAP 1/2" MK 25/3
322291	SUPPORT
330313	STEAM BOILER 18000KCAL/H
350764	BRACKET
381404	HOSE STEAM GAUGE
390627	PUMP SUPPORT
400583	MANIFOLD
441401	PRESSURE GAUGE 60 SCALO-4CR1/4
450516	THERMOSTAT SHIELD FOR 2 TERMOS



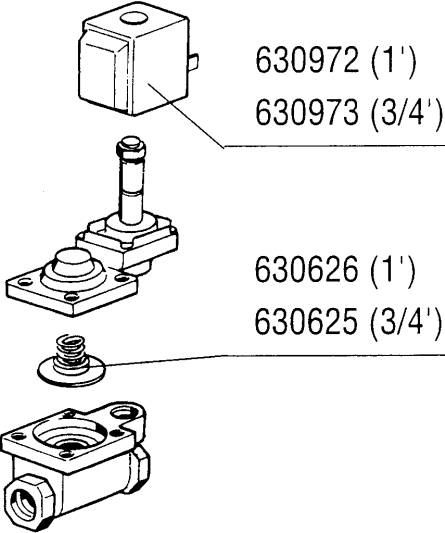
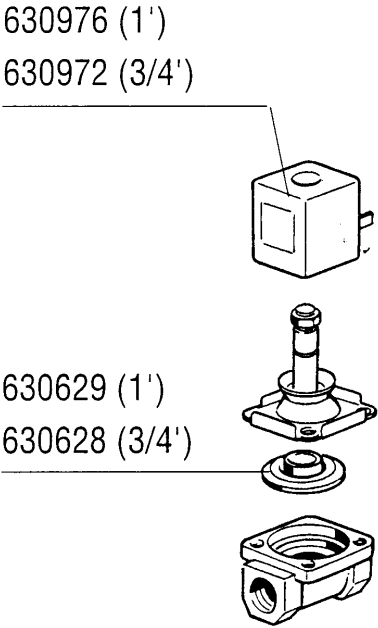
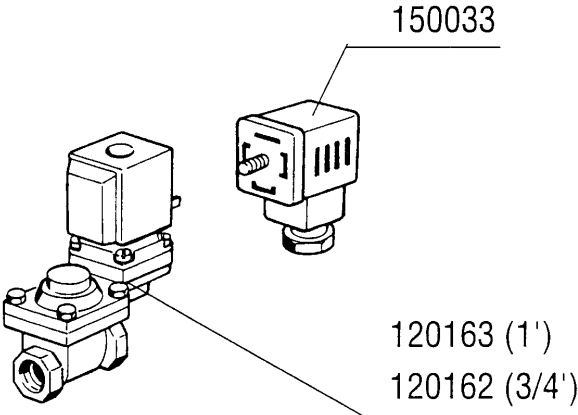
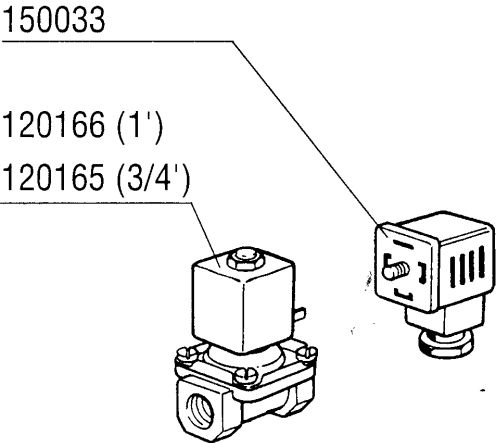

0 ÷ 2 bar

0,5 ÷ 2,5 bar

**18 - Steam solenoid valve**

<b>CODE</b>	<b>DESCRIPTION</b>
120162	SOLENOID VALVE L145R1Z734A 3/4
120163	SOLEN.VAL.ST.L145R1Z234A 1"24V
120165	SOLEN.VALVE ST.24V50HZ 3/4"
120166	STEAM SOLEN.VALVE 1" 24V-50
150033	CONNEC.F.SOLEN.VALVE 182.09.N
630625	KIT F.SOLEN.VALVE
630626	KIT FOR SOLENOID VALVE 145 1"
630628	KIT F.SOLEN.V.L153D1 3/4"
630629	KIT SOLENOID VALVE 1" STEAM L1
630972	COIL Z534A/V.24-L145A-3/4
630973	COIL Z614A/V.24-L145-3/4 A
630976	COIL Z114A/V24/50HZ L153-1"

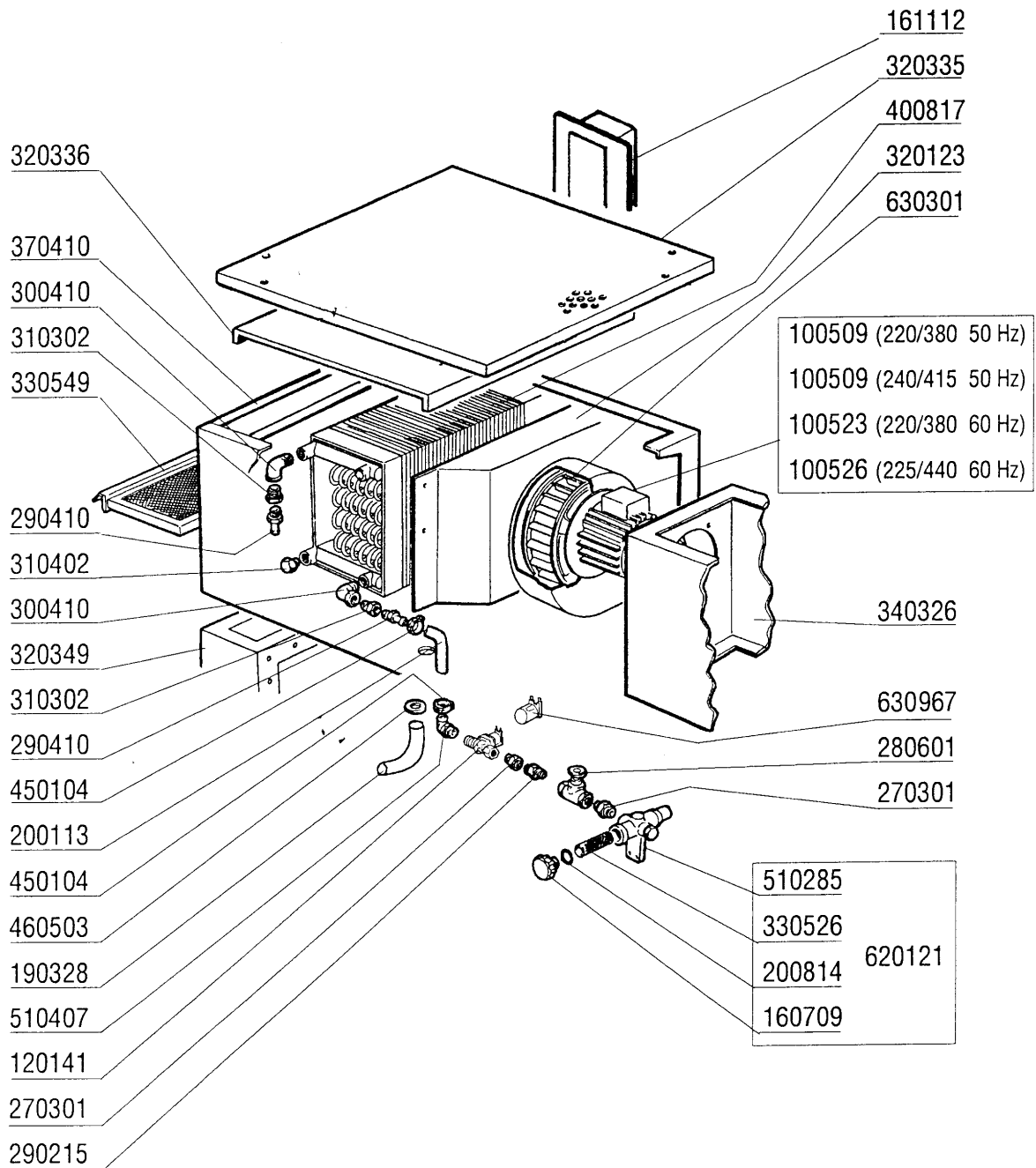

## 19 - Steam Condenser

CODE	DESCRIPTION
100509	FAN 0,75HP 220/415 V164/2
100523	FAN 0,75 HP 220/380V-60HZ
100526	FAN HP 0,75 255/440-60-VR184
120141	SOLEN.VALVE METAL.328000 D.1/2
160709	KNOB OF MANIFOLD F. SOLEN. VAL
161112	BACK COVER CHANNEL 300 S N
190328	DRAIN 3/4"
200113	RUBBER HOSE 12 X 22
200814	O-RING 34,52X41,58X3,53
270301	BRASS NIPPLES 1/2"
280601	GATE VALVE 1/2" BRASS
290215	1/2"BSP M/F UNION BRASS
290410	NIPPLE 1/2"
300410	ELL 3/4" MF
310302	NIPPLE 3/4"-1/2"
310402	PLUG 3/4"
320123	VORTEX BREAKER F.STEAM CONDENS
320335	TOP PANEL FOR STEAM CONDENSER
320336	TOP PANEL FOR STEAM CONDENSER
320349	TOP FOR SPLASH HOOD WITH STEAM
330526	FILTERS 22X28 SOLENOID V.MANIF
330549	CONDENSATE UNIT FILTER
340326	PANEL
370410	CONDENSER MODULE
400817	BATTERY FOR STEAM CONDENSER +
450104	CLAMP FE ZN H=12,5 15-24
460503	SEALING WASHER 38X27X2(3/4)
510285	SOLENOID VALVE MANIFOLD - BRAS
510407	NIPPLE FOR BOILER N S
620121	TWIN SOLENOID VALVE MANIFOLD
630301	FAN IMPELLOR FOR 100509
630967	COIL V24/50HZ E/V 328002

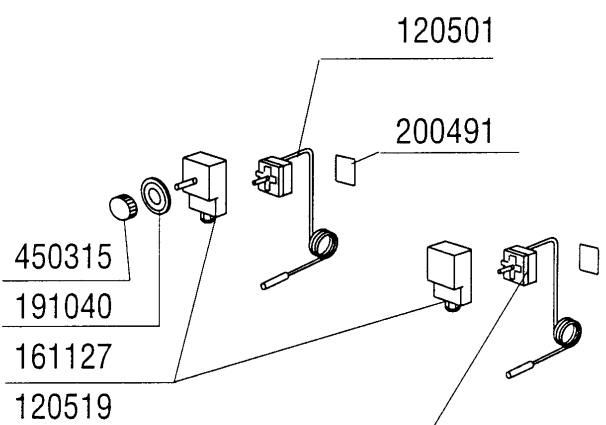
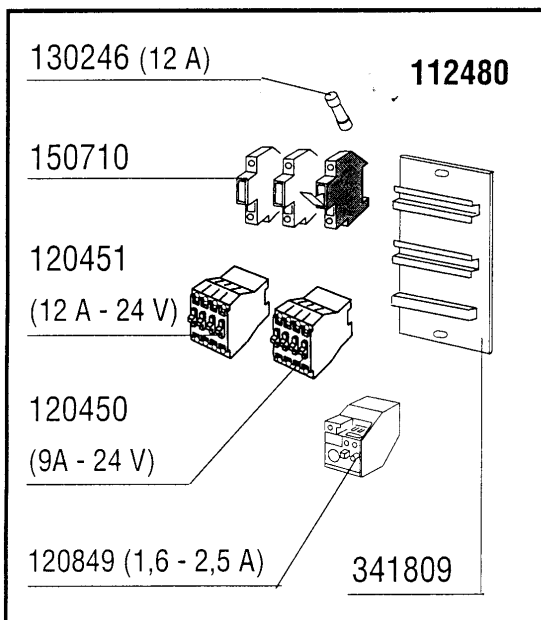
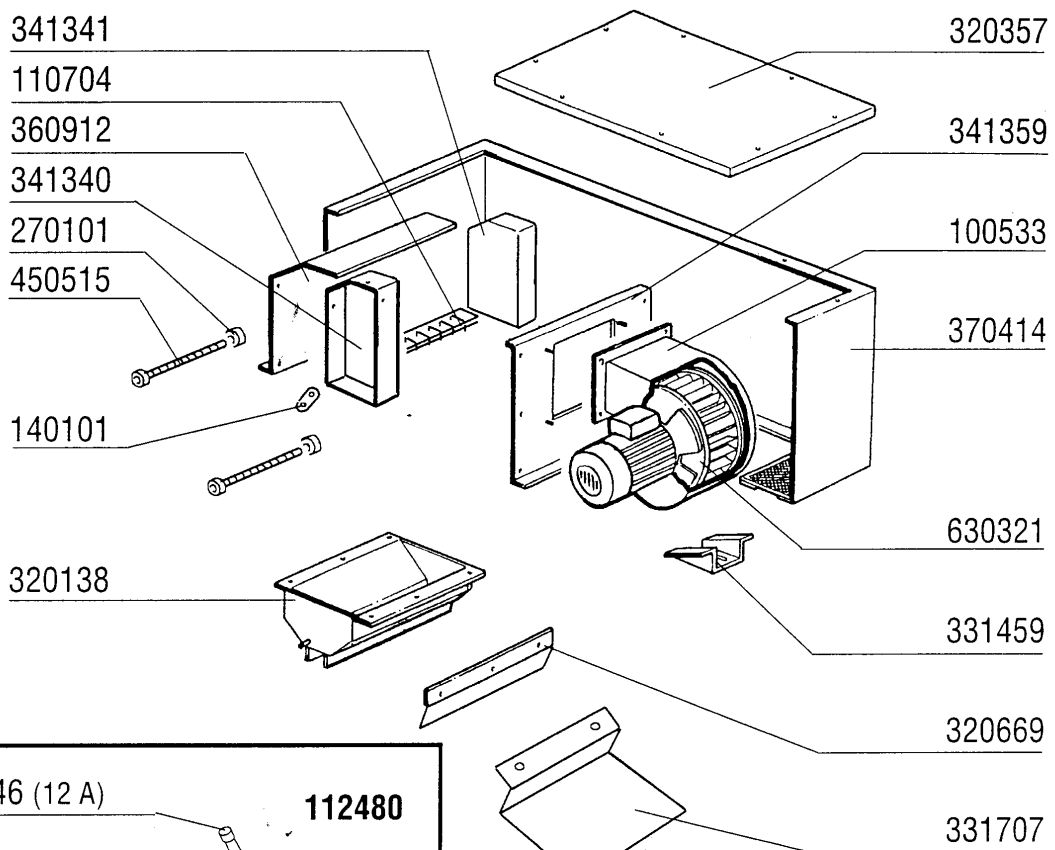

## 20 - Blower Dryer

CODE	DESCRIPTION
100533	FAN HP 1 220-240-380-415V VRP2
110704	HEAT.ELEMENT/DRYING 1000W 220V
112480	WIRING DRYER "AC91/101/95/105"
120450	CONTACTOR 9A 24V 4KW
120451	CONTACTOR 12A 24V 5,5KW
120501	THERMOSTAT 30/90°C
120519	SECURITY THERMOSTAT 95-125°C
120849	OVERLOAD RELAY 1,6/2,5A
130246	FUSE 10.3X38 12A GF13312
140101	BRASS CONNECT. PLATE HEAT.ELEM
150710	FUSE CARRIER 10,3X38 ART.21401
161127	BOX FOR THERMOSTAT
191040	FRAME F.THERMOSTAT KNOB
200491	BACK GASKET OF THERMOSTAT BOX
270101	HEXAGON LOCK NUT 1/2"
320138	DEFLECTOR F. DRYER
320357	DRYER COVER
320669	FIXING PLATE
331459	BRACKET FOR DRYING VENTILATOR
331707	BRACKET
341340	LEFT SUPPORT
341341	RIGHT SUPPORT
341359	FAN SUPPORT
341809	DRYER SUPPORT AC
360912	BACK PANEL
370414	DRYING MODULE
450315	KNOB F. THERMOSTAT 90°C
450515	STAINL.ST.SHIELD FOR 1 THERMOS
630321	FAN IMPELLOR FOR C 100533 1HP

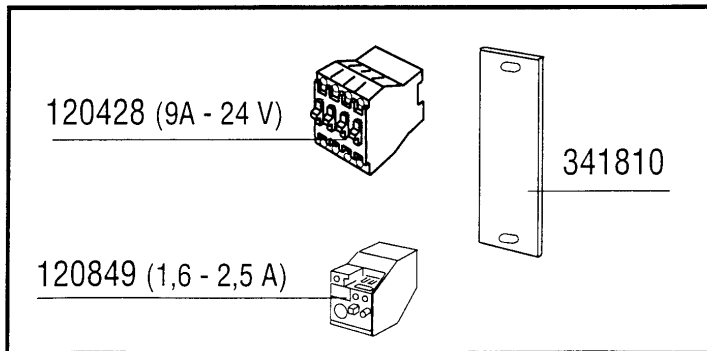
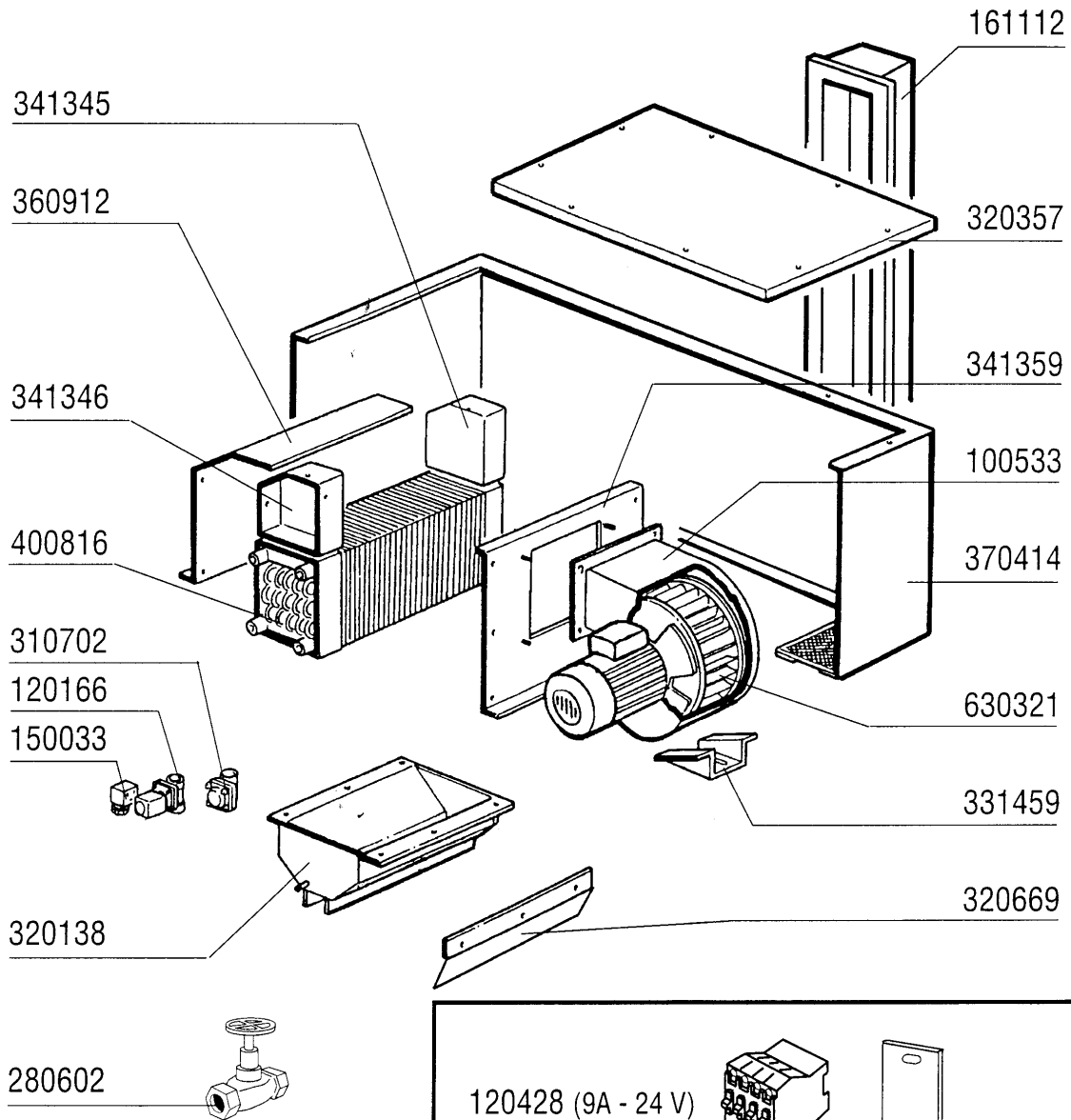

21 - Steam Blower Dryer

CODE	DESCRIPTION
100533	FAN HP 1 220-240-380-415V VRP2
120166	STEAM SOLEN.VALVE 1" 24V-50
120428	CONTACTOR 9A 24V 50HZ
120849	OVERLOAD RELAY 1,6/2,5A
150033	CONNEC.F.SOLEN.VALVE 182.09.N
161112	BACK COVER CHANNEL 300 S N
280602	GATE VALVE 3/4" BRASS
310702	STEAM TRAP 1/2" MK 25/3
320138	DEFLECTOR F. DRYER
320357	DRYER COVER
320669	FIXING PLATE
331459	BRACKET FOR DRYING VENTILATOR
341345	RIGHT PANEL
341346	LEFT PANEL
341359	FAN SUPPORT
341810	STEAM CONDENSER SUPPORT FOR AC
360912	BACK PANEL
370414	DRYING MODULE
400816	BATTERY FOR DRYING (6KW) S
630321	FAN IMPELLOR FOR C 100533 1HP



22 - Splash guard with ventilator

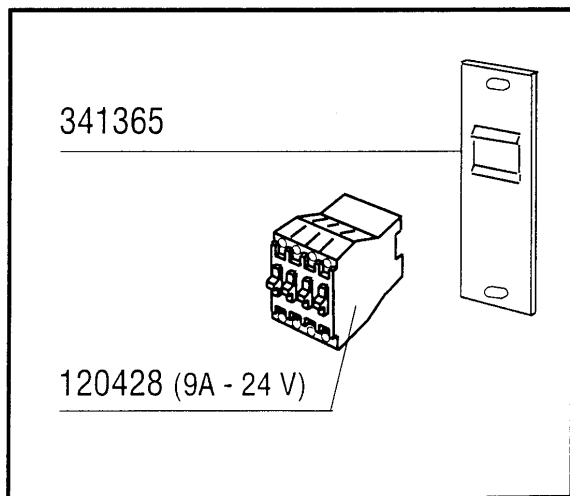
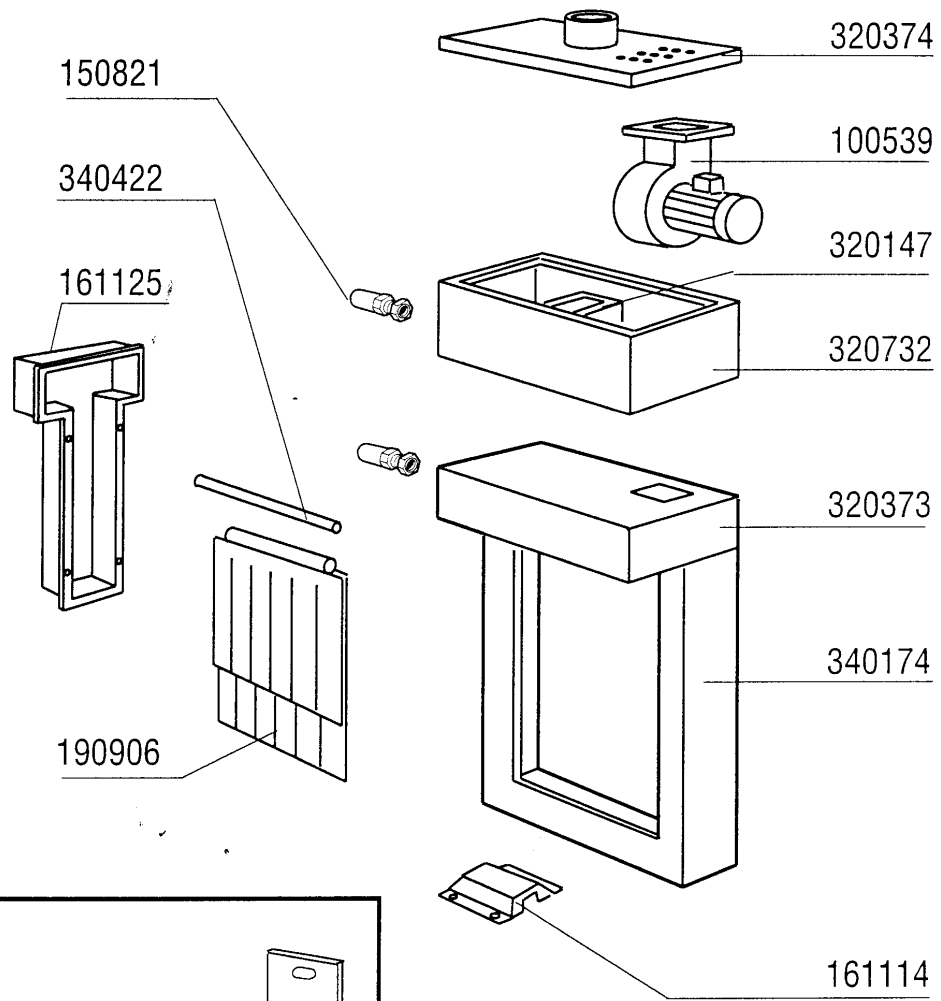

## 22 - Splash guard with ventilator

<b>CODE</b>	<b>DESCRIPTION</b>
100539	EXHAUST FAN F.SPLASH GUARD 220
111359	FAN WIRING
120428	CONTACTOR 9A 24V 50HZ
150821	CONNECTOR
161114	END COVER OF PAWL BAR S3-S2900
161125	BACK COVER CHANNEL S NL
190906	CURTAIN IN/OUT 620X480
320147	VORTEX BREAKER
320373	TOP CAPOT SE
320374	TOP CAPOT SE
320732	PANEL
340174	HOOD
340422	SHAFT FOR CURTAIN AC-ACR
341365	PANEL SUPPORT F.STEAM CONDENSE